

Examples of Control Systems

Dr. Laith Abdullah Mohammed

Department of Production Engineering & Metallurgy, UOT

Email: dr.laith@uotechnology.edu.iq

Website: <http://www.uotechnology.edu.iq/dep-production/laith/index.html>

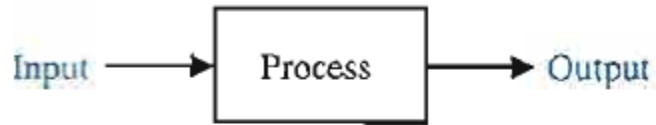

Process to be controlled



Open Loop Control System (without feedback)

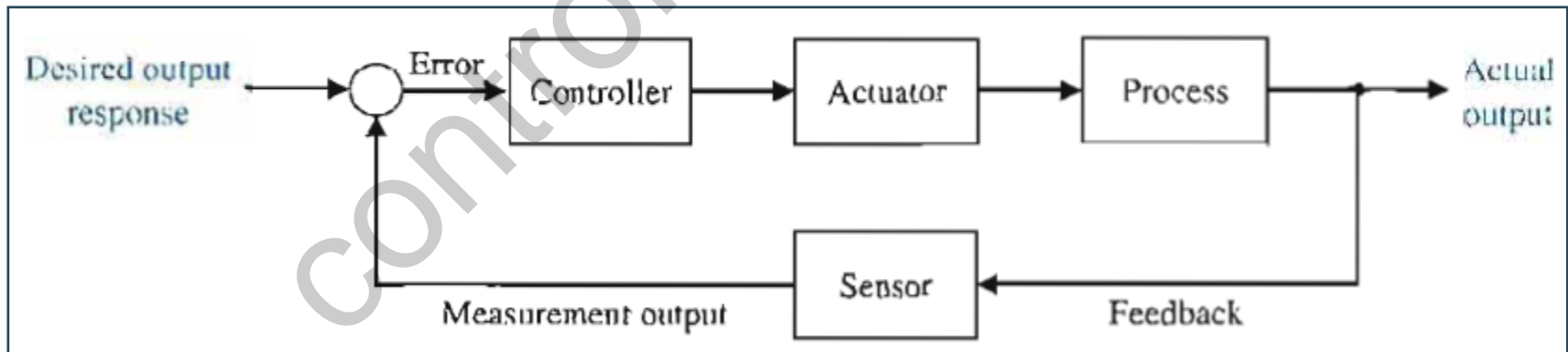

Closed Loop Feedback Control System (with feedback)

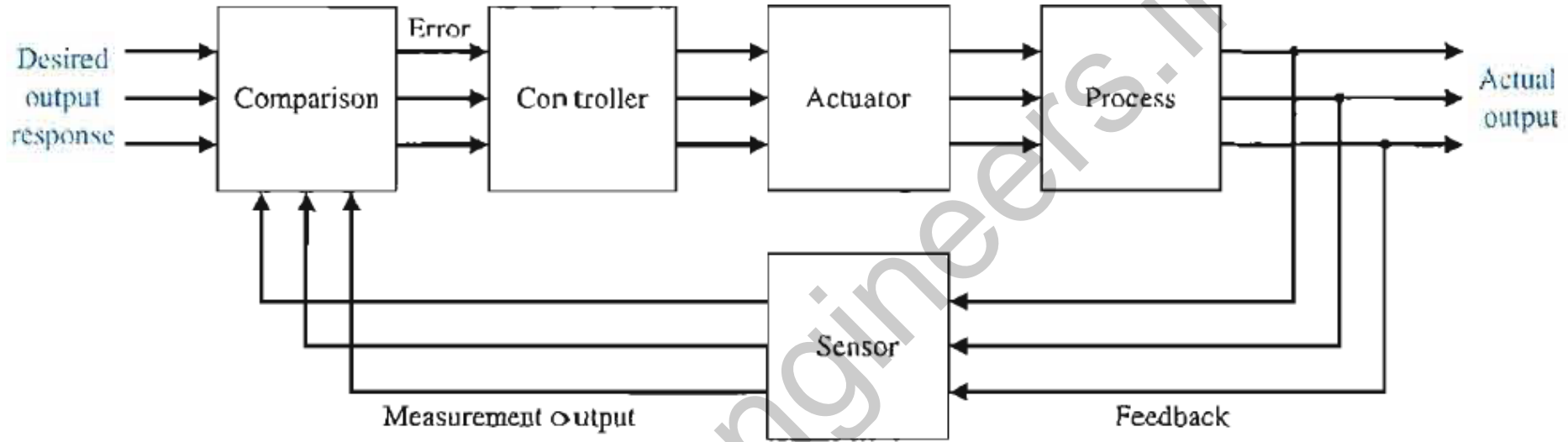

Multivariable Control System

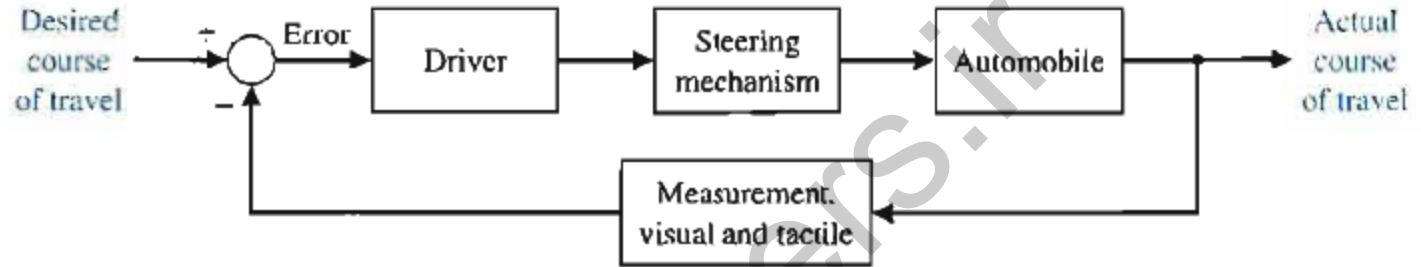

Example [1]: Automobile Steering Control System

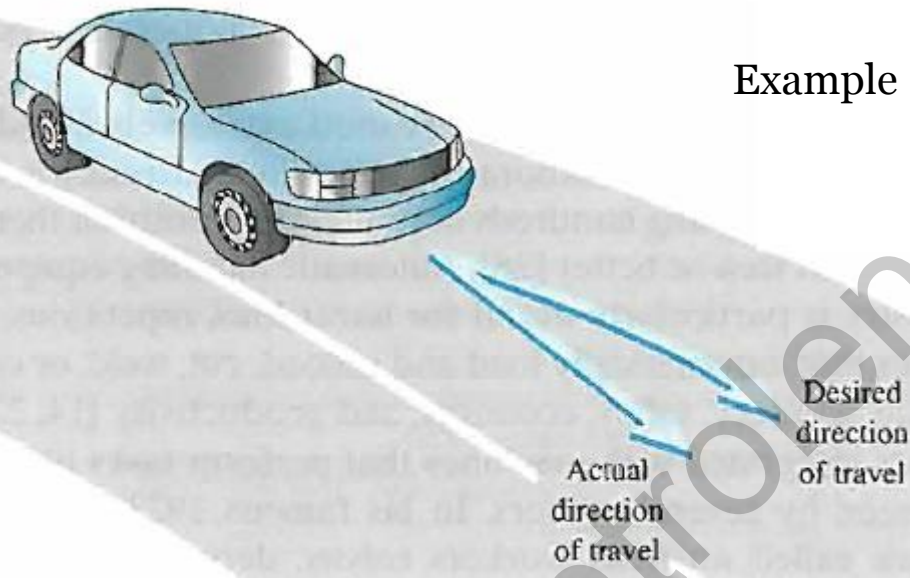

The driver uses the difference between the actual and the desired direction of travel to generate a controlled adjustment of steering wheel

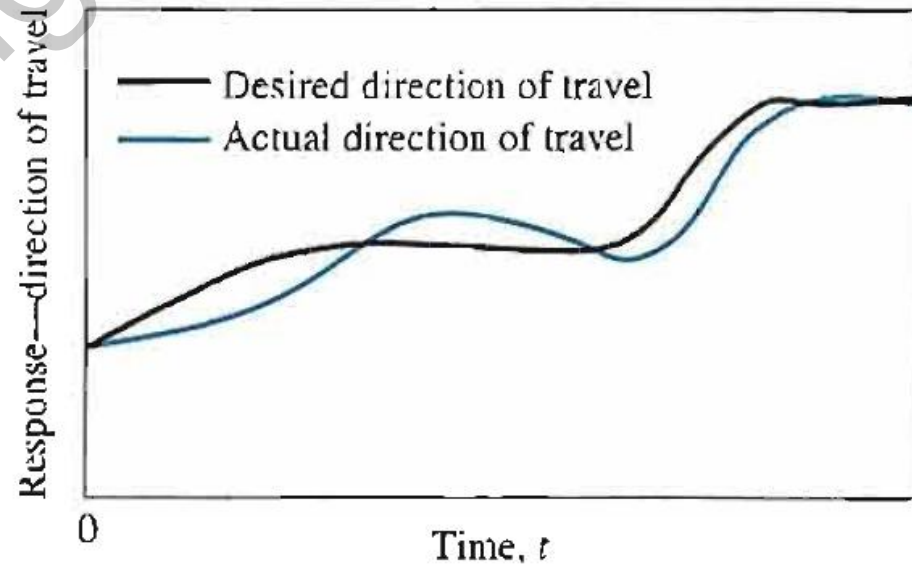

Typical direction of travel response

Example [2]: Automobile interior cabin temperature control system

Many luxury automobiles have thermostatically controlled air-conditioning systems for the comfort of the passengers. Sketch a block diagram of an air-conditioning system where the driver sets the desired interior temperature on a dashboard panel. Identify the function of each element of the thermostatically controlled cooling system.

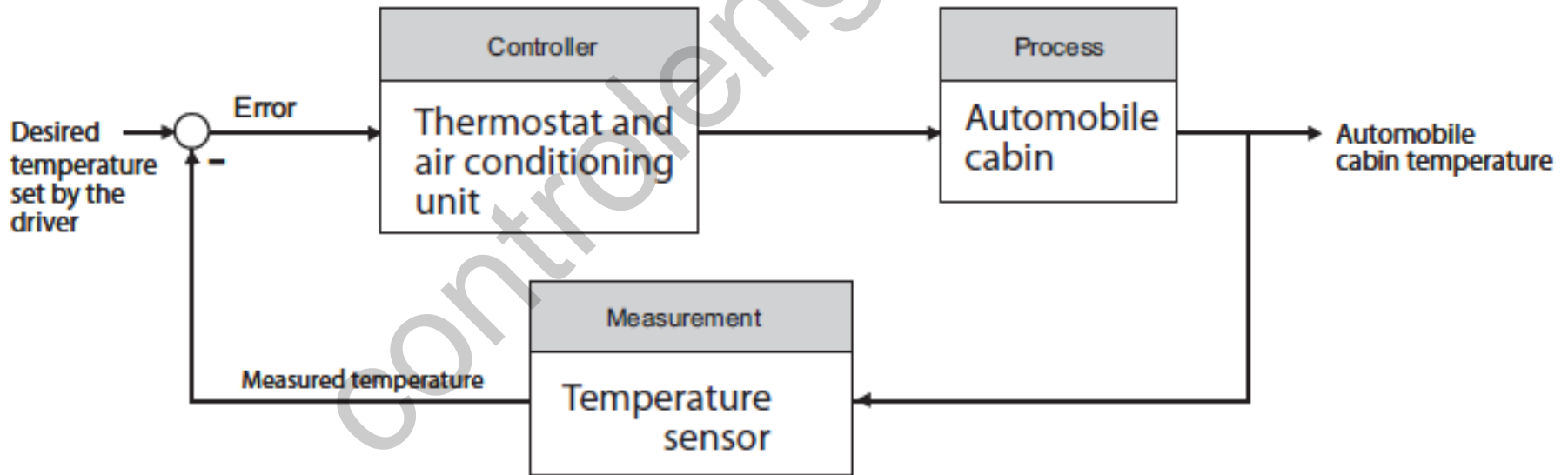

Example [3]: A chemical composition control system

In a chemical process control system, it is valuable to control the chemical composition of the product. To do so, a measurement of the composition can be obtained by using an infrared stream analyzer, as shown in Figure. The valve on the additive stream may be controlled. Complete the control feedback loop, and sketch a block diagram describing the operation of the control loop.

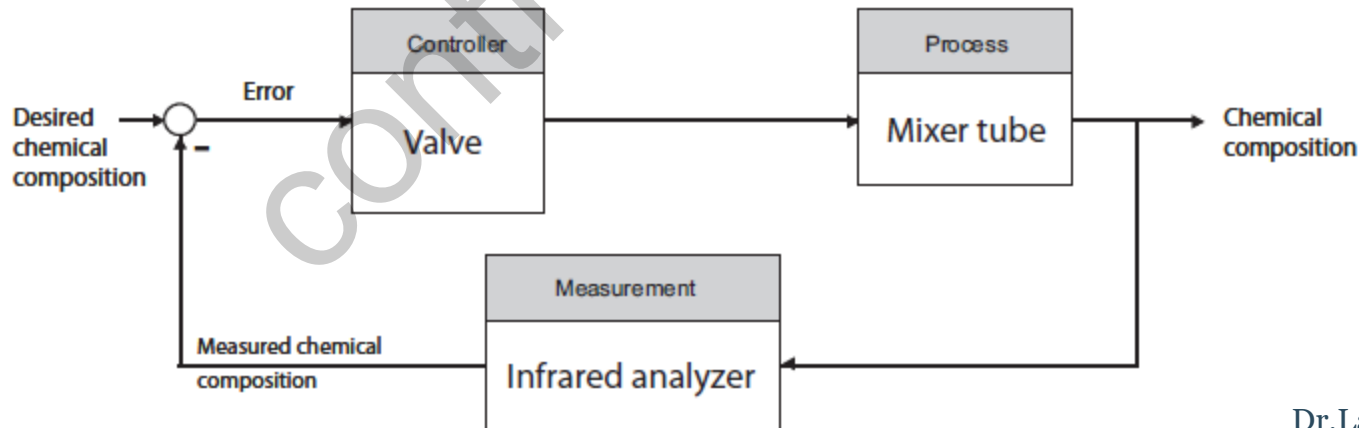
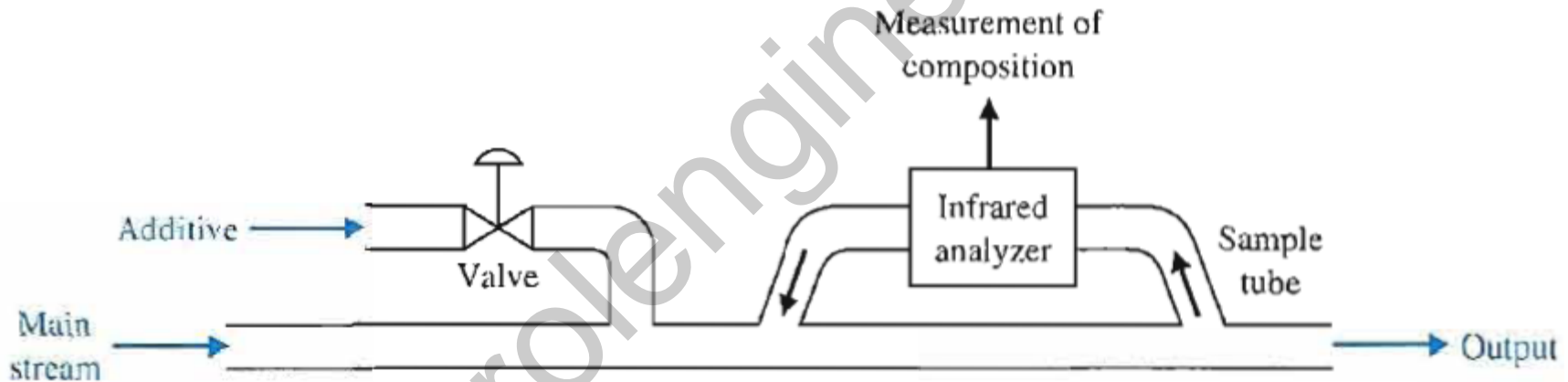

Example [4]: A light seeking control system

A light-seeking control system, used to track the sun, is shown in Figure . The output shaft, driven by the motor through a worm reduction gear, has a bracket attached on which are mounted two photocells. Complete the closed-loop system so that the system follows the light source.

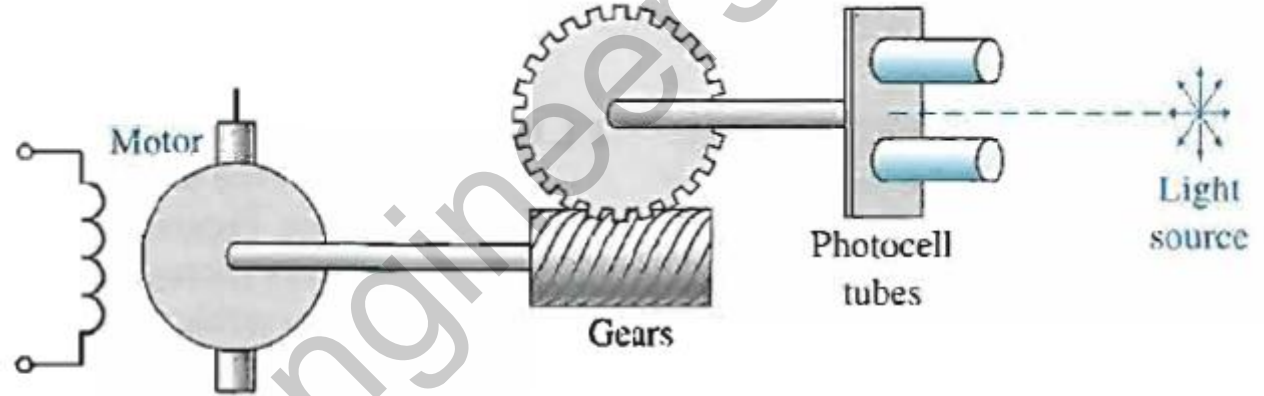

A photocell is mounted in each tube. The light reaching each cell is the same in both only when the light source is exactly in the middle as shown.

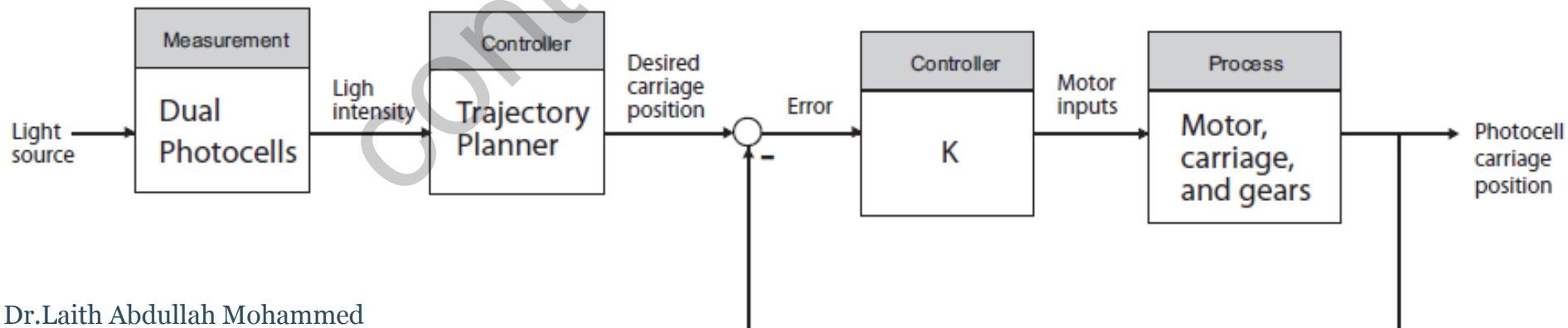

Example [5]: An aircraft flight path control system using GPS

The role of air traffic control systems is increasing as airplane traffic increases at busy airports. Engineers are developing air traffic control systems and collision avoidance systems using the Global Positioning System (GPS) navigation satellites. GPS allows each aircraft to know its position in the airspace landing corridor very precisely. Sketch a block diagram depicting how an air traffic controller might use GPS for aircraft collision avoidance.

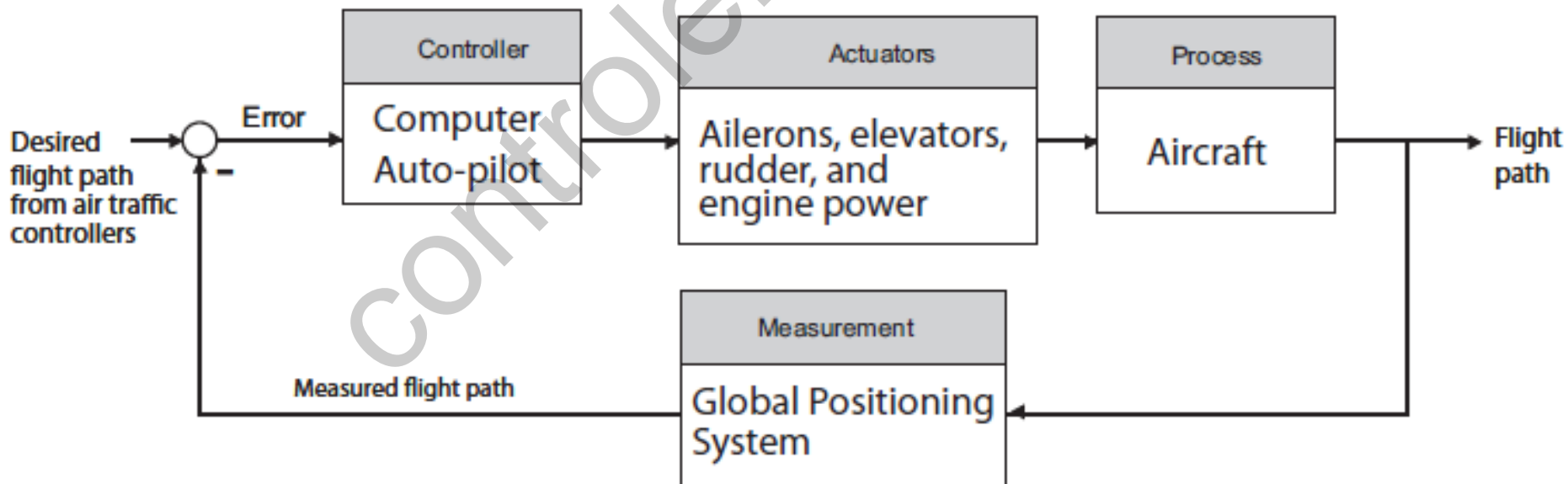

Example [6]: A car control speed system

In a car, to control speed, there is accelerator and break. Suppose break is not there, will you be able to decrease the speed when desired. Explain the need for two control signals (accelerator and break).

A control system to keep a car at a given relative position offset from a lead car:

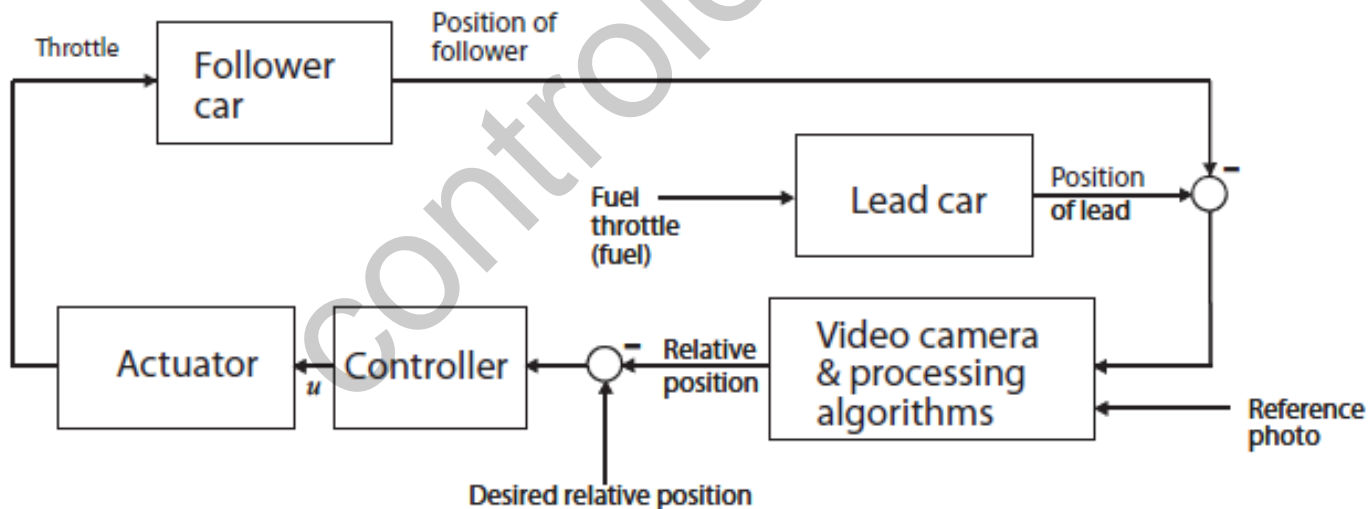

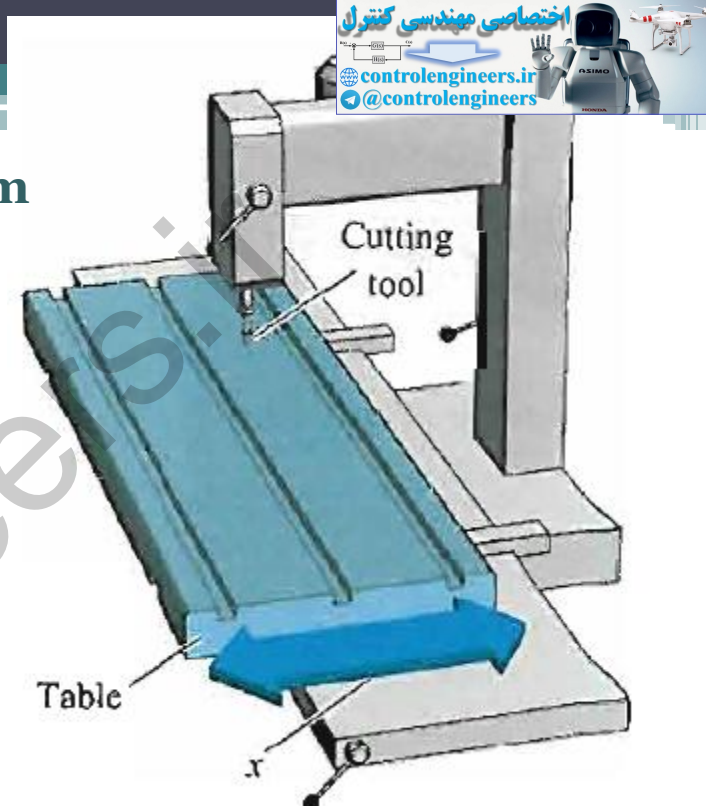

Example [7]: NC machine position control system

Increasingly stringent requirements of modern, high-precision machinery are placing increasing demands on slide systems. The typical goal is to accurately control the desired path of the table shown in Figure. Sketch a block diagram model of a feedback system to achieve the desired goal. The table can move in the x direction as shown.

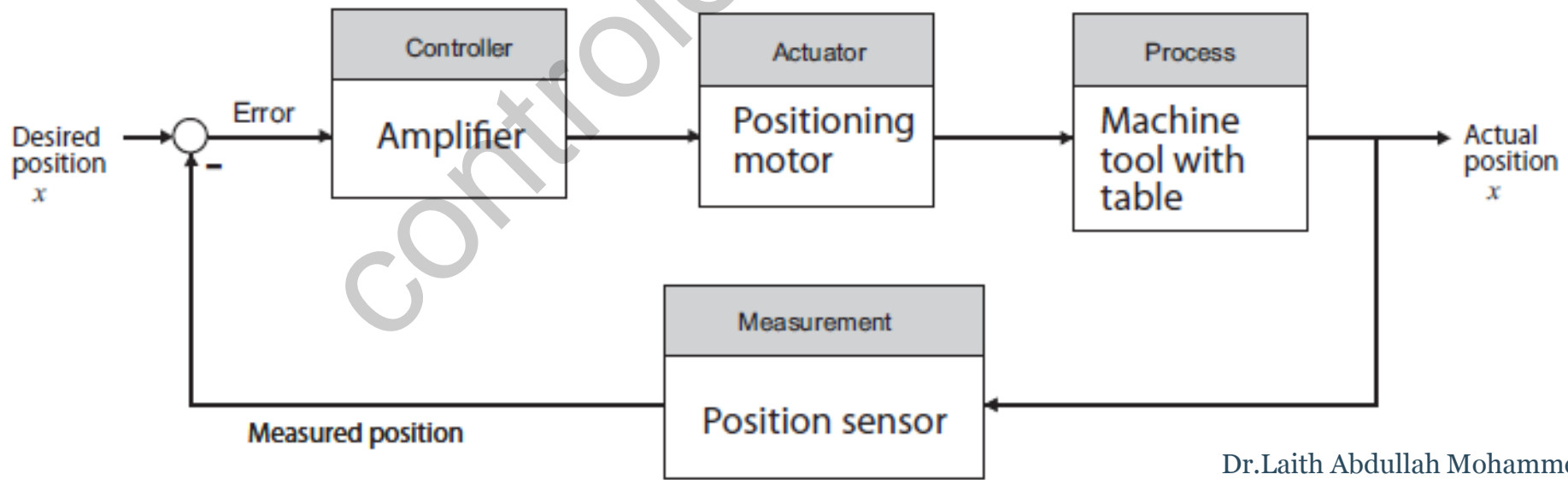

Example [8]: Robot welder

A large, braced robot arm for welding large structures is shown in Figure _____. Sketch the block diagram of a closed-loop feedback control system for accurately controlling the location of the weld tip.

